



RMIA Lunch & Learn

July 18, 2021

Scot Zajic
Vice President – Legislative Affairs



Strategic Business Units

Founded in 1947...

Safelite Group is the largest vehicle glass and claims management specialists in the United States.



In 2007...

Safelite was acquired by Belron. As the world's largest company dedicated to vehicle glass, global best practices are shared worldwide.



Largest vehicle glass repair and replacement company in the U.S.



Claims management for fleet and P&C Insurance industries

Our Impact



- **11M** customers served companywide
- **7M** customers served through Safelite AutoGlass
- **6,900** technicians
- **16,000** associates
- **91** warehouses and **2** distribution centers
- Coverage for **100%** of U.S. drivers in all 50 states
- **87%** NPS

Advanced Safety Systems

Today's vehicles are rolling computers



Avg. vehicle has 80 ECUs* and 60-100 sensors enabling features like:

- Seat occupancy (airbag deployment)
- Drowsiness monitoring
- **Automatic/Emergency Braking**
- **Augmented reality navigation**
- **Forward Collision Warning**
- **Adaptive cruise**
- **Lane Keeping**

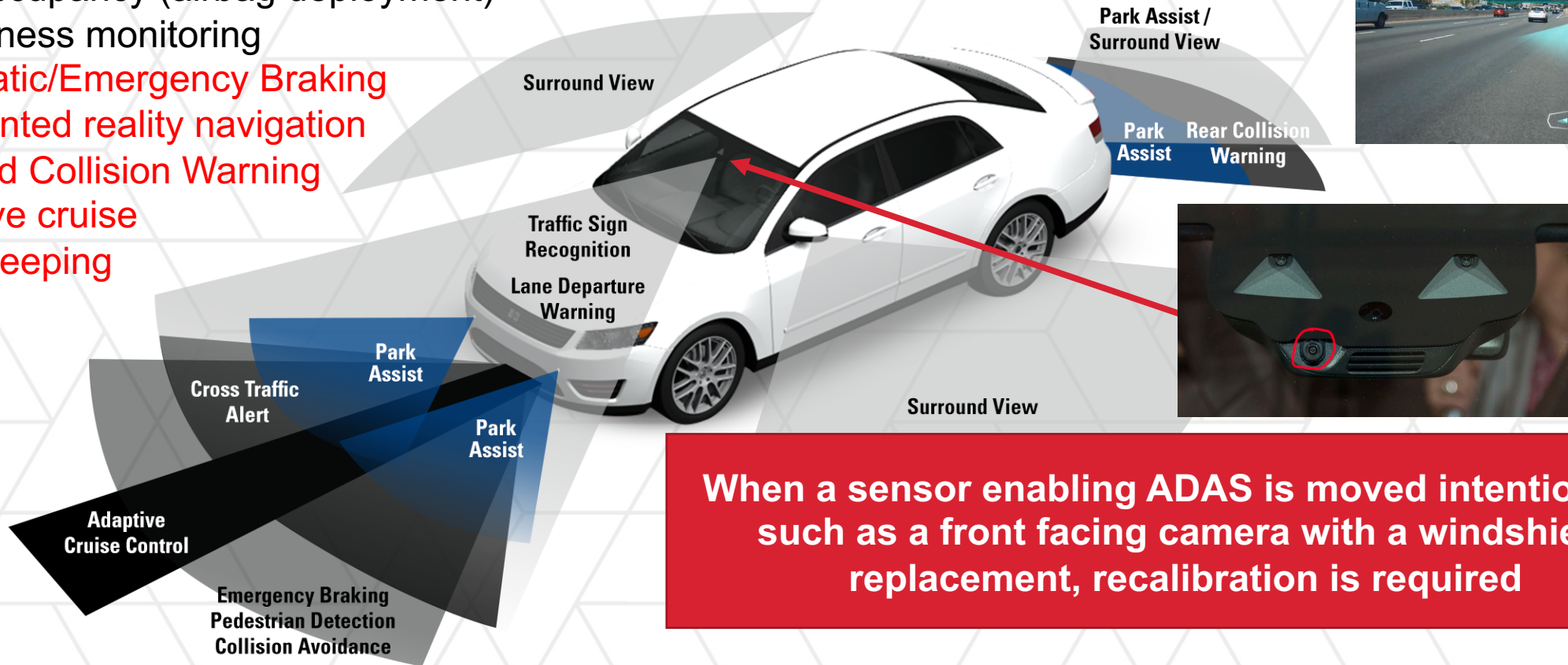

When a sensor enabling ADAS is moved intentionally, such as a front facing camera with a windshield replacement, recalibration is required



What is Recalibration and why is it required?

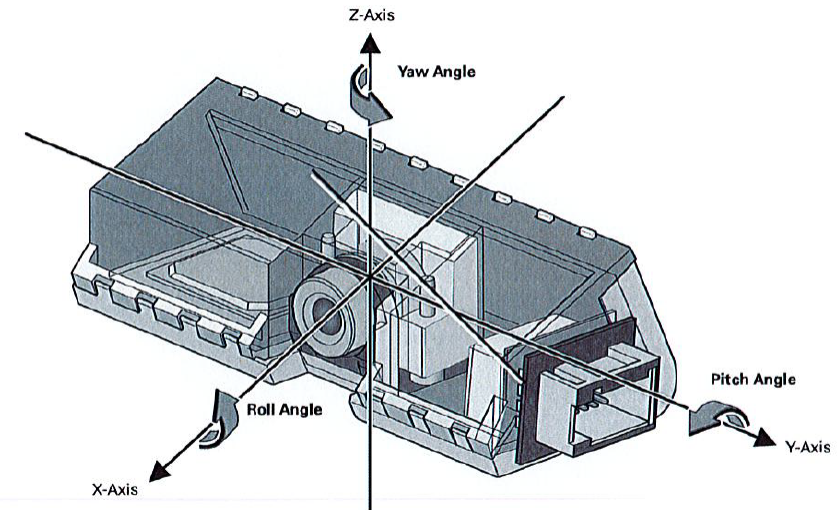
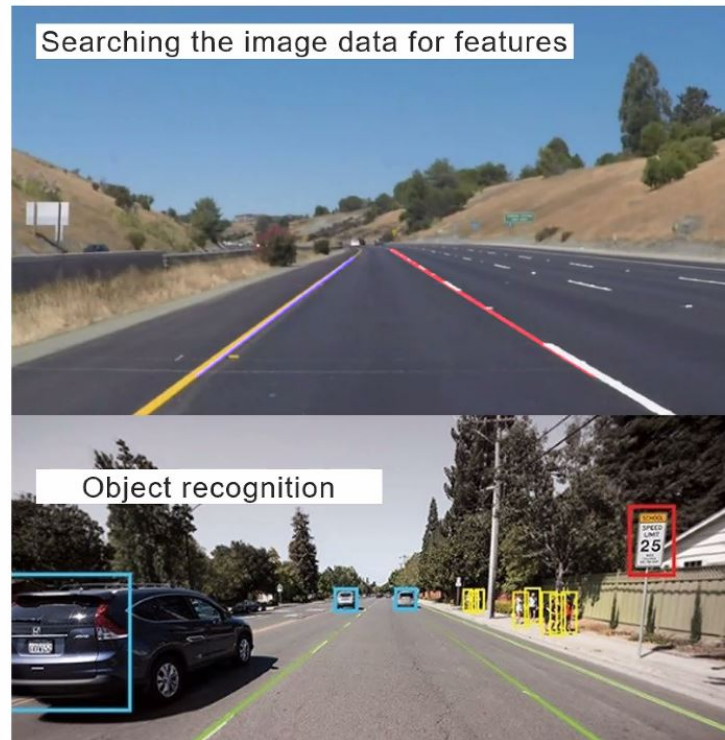
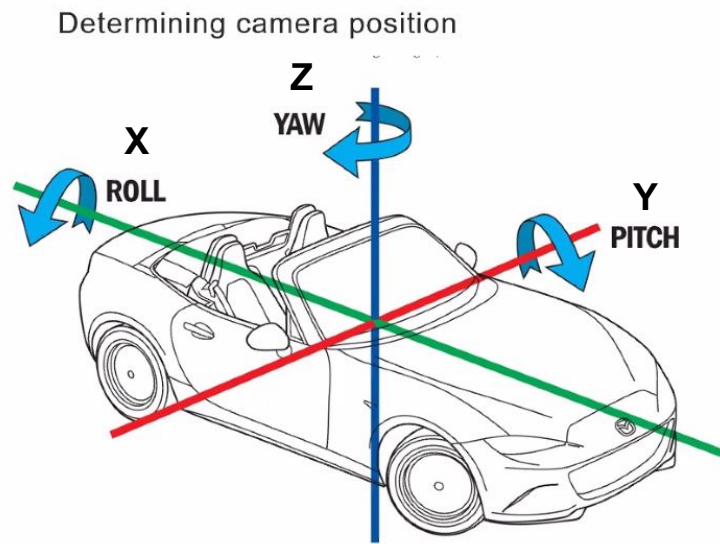

- When the windshield is replaced, the camera sensor attached to the glass is moved
- Camera does not know its position in space – its ability to recognize objects and distance is impacted
- Recalibration enables the vehicle's systems to again determine the orientation angles of the camera



What is Recalibration and why is it required?

Determining camera position

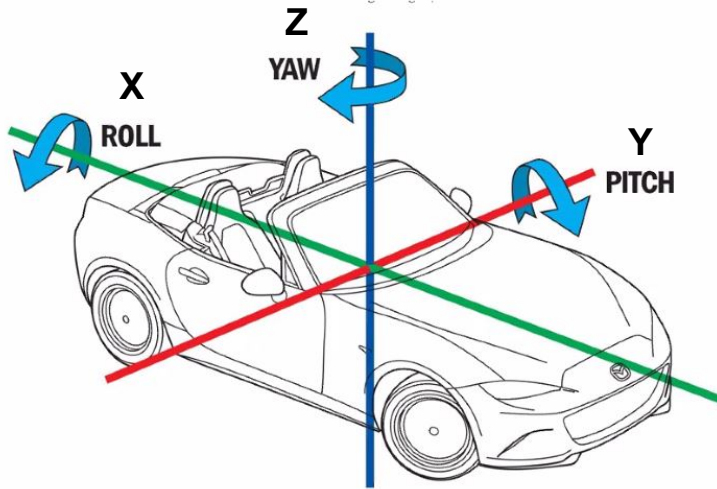

Searching the image data for features



Object recognition

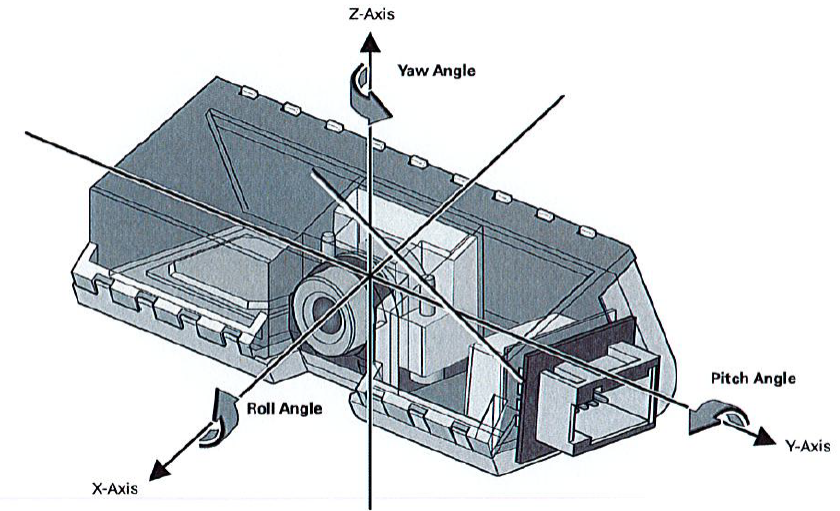

- Static
- Dynamic
- Dual

- Unique to each VM
- \$300-\$400 per
- Frequency/Severity issues

Growth in Front Camera Penetration Rate will continue



From non-existent to +/- 25% of carpark in a few short years

Model year 2021 vehicles approaching 80% penetration rate

Front Camera Penetration Rate by Model Year

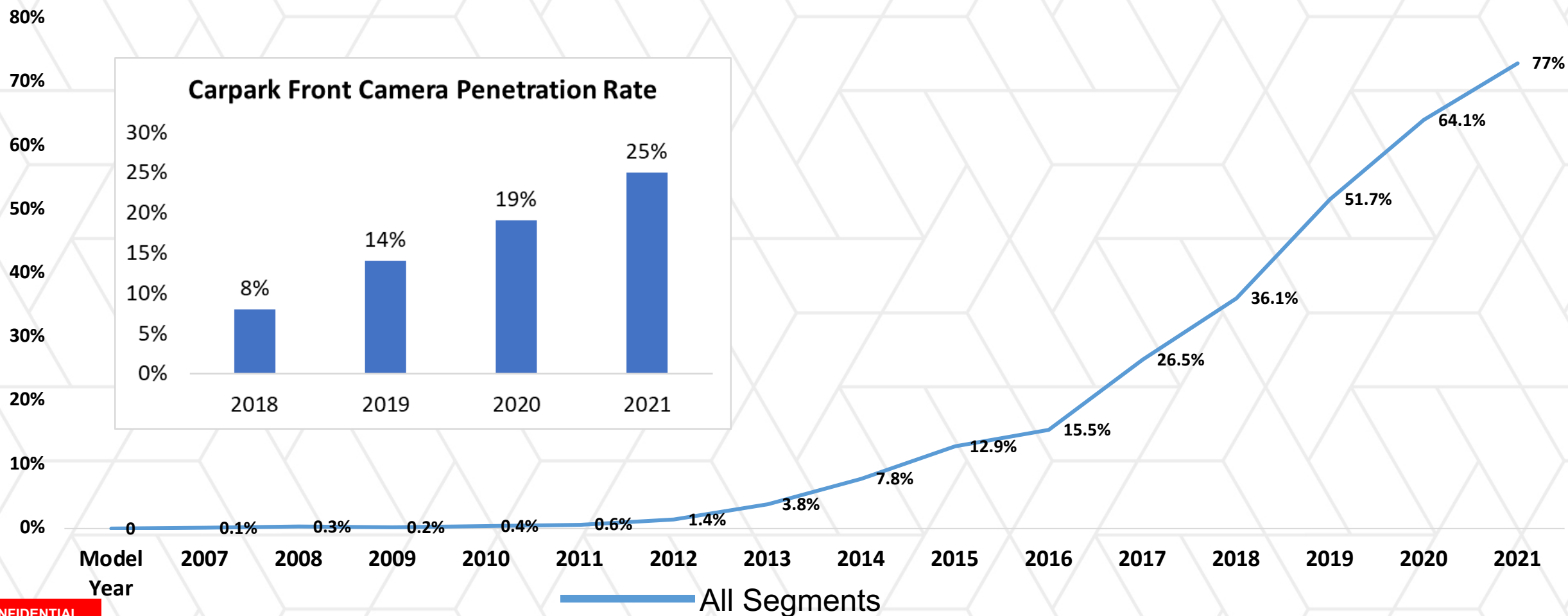

ADAS Umbrella

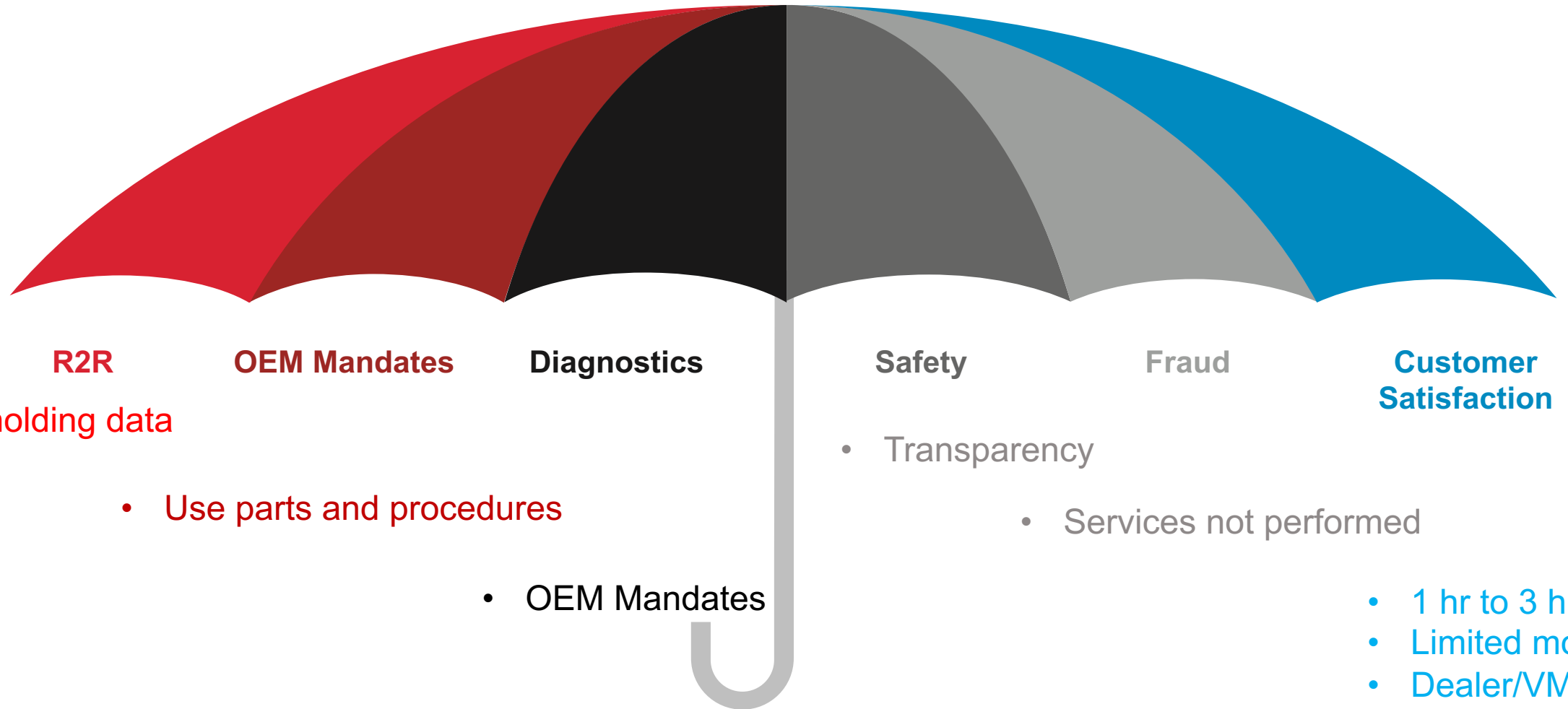

ADAS Policy Issues

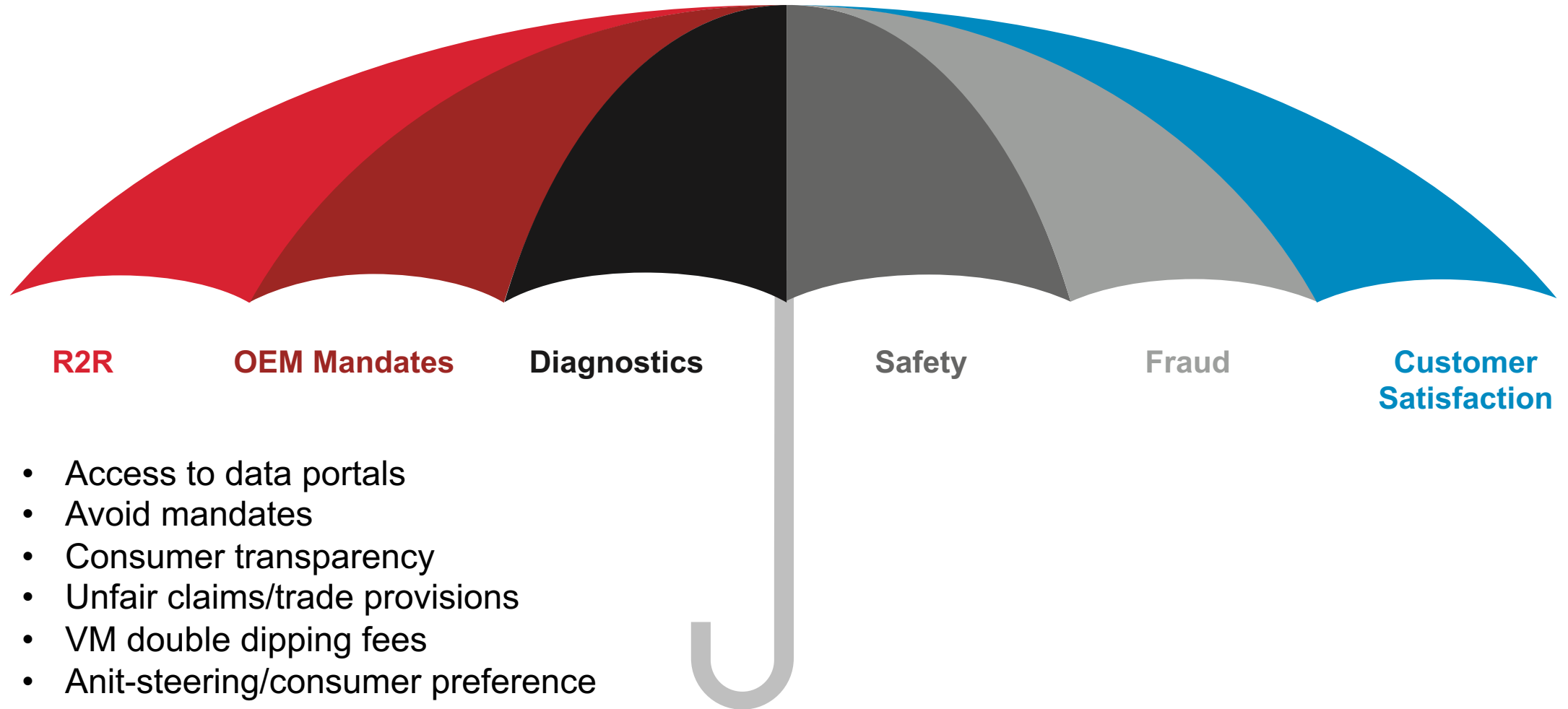

Thank You

